

▼ Shown from left to right: V-152, V-66, V-82, V-161, V-42, V-17

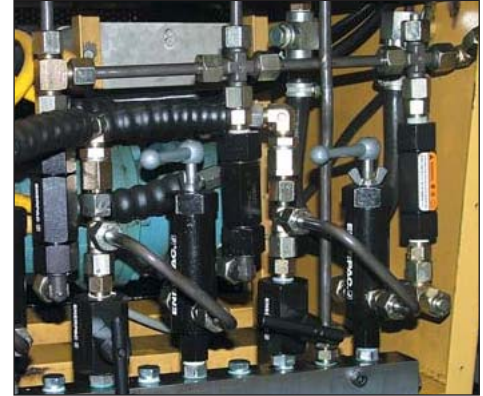

Your Hydraulic Control Solution

▼ The V-152 Pressure Relief Valve limits the pressure or force developed in the hydraulic system.



- All valves are rated for 10,000 psi operating pressure
- All valves feature NPTF porting to insure against leakage at rated pressure
- All valves are painted, coated, or plated for corrosion resistance



Valve Applications

To see these valves used in typical hydraulic circuits, please see our "Yellow Pages".

Page: 114

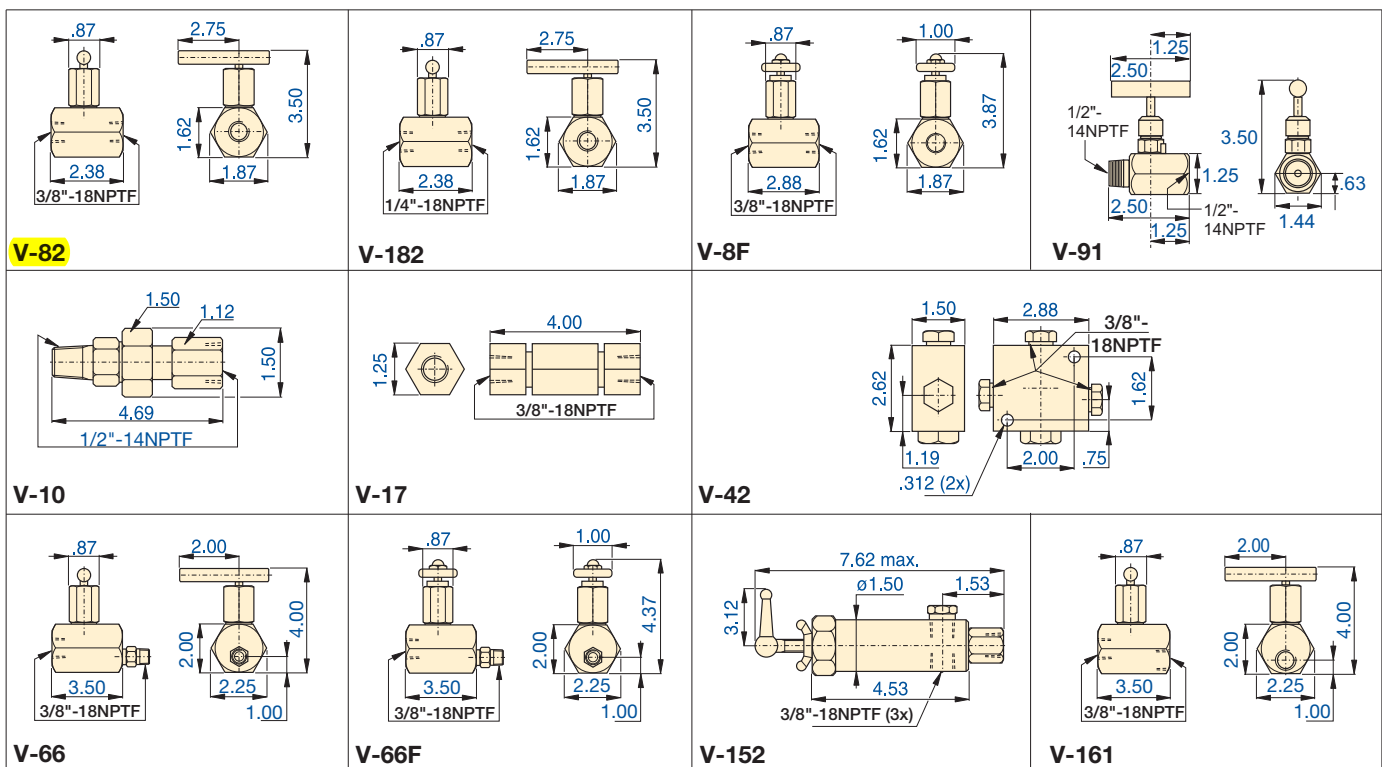

Valve Dimensions in inches.

Flow and Pressure Control Valves



Premounted Manifold

For two or four port manifold with integral flow control valves, see the manifold page of the System Components section.

Page: 120



Fittings

For additional fittings see the fitting page of the System Components section.











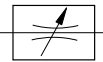

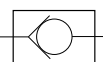

Page: 121

V Series

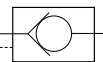

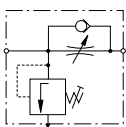
Maximum Operating Pressure:

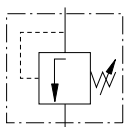
10,000 psi

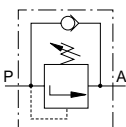
Valve Type and Model Number	Description	Hydraulic Symbol
Needle Valve V-82 V-182F V-8F	 <p>V-82: To control cylinder speed. Can also be used as shut-off valve for temporary load holding. 1/4" NPTF female ports. Also suitable for gauge snubbing. V-8F: Similar to V-82, but with very fine metering for precise flow control. V-182: Same as V-82, but with 3/8" NPTF female ports. Not recommended as shut-off valve.</p>	
Snubber Valve V-91	 <p>V-91: Adjustable for metering oil out of a gauge to prevent snapping of gauge pointer when load or pressure is suddenly released. Also suitable as shut-off valve to protect the gauge during high cycling applications. 1/2" NPTF male and female threads for use with GA-1, GA-2 or GA-4 gauge adaptors.</p>	
Auto Damper® Valve V-10	 <p>V-10: To be used when gauge pressure must be monitored during high cycle applications. Creates a flow resistance when load is released suddenly. No adjustments are necessary. 1/2" NPTF male and female threads for use with GA-1, GA-2 or GA-4 gauge adaptors.</p>	
Check Valve V-17	 <p>V-17: Ruggedly built to resist shock and operate with low pressure drop. Closes smoothly without pounding. 3/8" NPTF female ports.</p>	
Pilot Operated Check Valve V-42	 <p>V-42: Can be mounted at the cylinder to hold the load in case of system pressure loss. Normally used with double-acting cylinders where pilot port receives pressure from a Tee-fitting in the cylinder retract line. 3/8" NPTF female ports. Pilot pressure ratio 14% (6.5:1).</p>	
Manually Operated Check Valve V-66* V-66F	 <p>V-66: Used for load holding applications with single and double acting cylinders. Valve is manually opened to allow oil to flow back to tank when cylinder retracts. V-66F: Similar to V-66, but with very fine metering capability for precise flow control. Not designed for load holding applications.</p>	
Pressure Relief Valve V-152*	 <p>V-152: Limits pressure developed by the pump in hydraulic circuit, thus limiting the force created by other components. Valve opens whenever preset pressure is reached. To increase pressure setting, turn handle clockwise. Includes: • 3 ft return line hose kit • ±3% repeatability • 800-10,000 psi adjustment range.</p>	
Sequence Valve V-161	 <p>V-161: To control oil flow to a secondary circuit. Flow is blocked until system pressure rises to the V-161 setting. When this pressure level is reached, the V-161 opens to allow flow to the secondary circuit. A pressure differential is always maintained between the primary and secondary circuit. Min. operating pressure: 2000 psi.</p>	

* See page 56-57 for more information on extreme pressure and flow control valves.